

# WOOD CHIPS AND SAWDUST APPLICATION



# SUMMARY

- I) PROCESS STEP
- II) OBJECTIVES OF THE MEASURE
- III) TECHNICAL CHARACTERISTICS OF THE APPLICATION
- IV) EDIT NIR SOLUTION
- V) RESULTS
- VI) REFERENCES



# I) PROCESS STEP

## 1) ADDING SAWDUST IN THE PRODUCTION



reception



Drying



Addition in the  
product and  
injection to  
supply the  
furnace



# 1) PROCESS STEP

## 2) MANUFACTURING PANNELS OSB

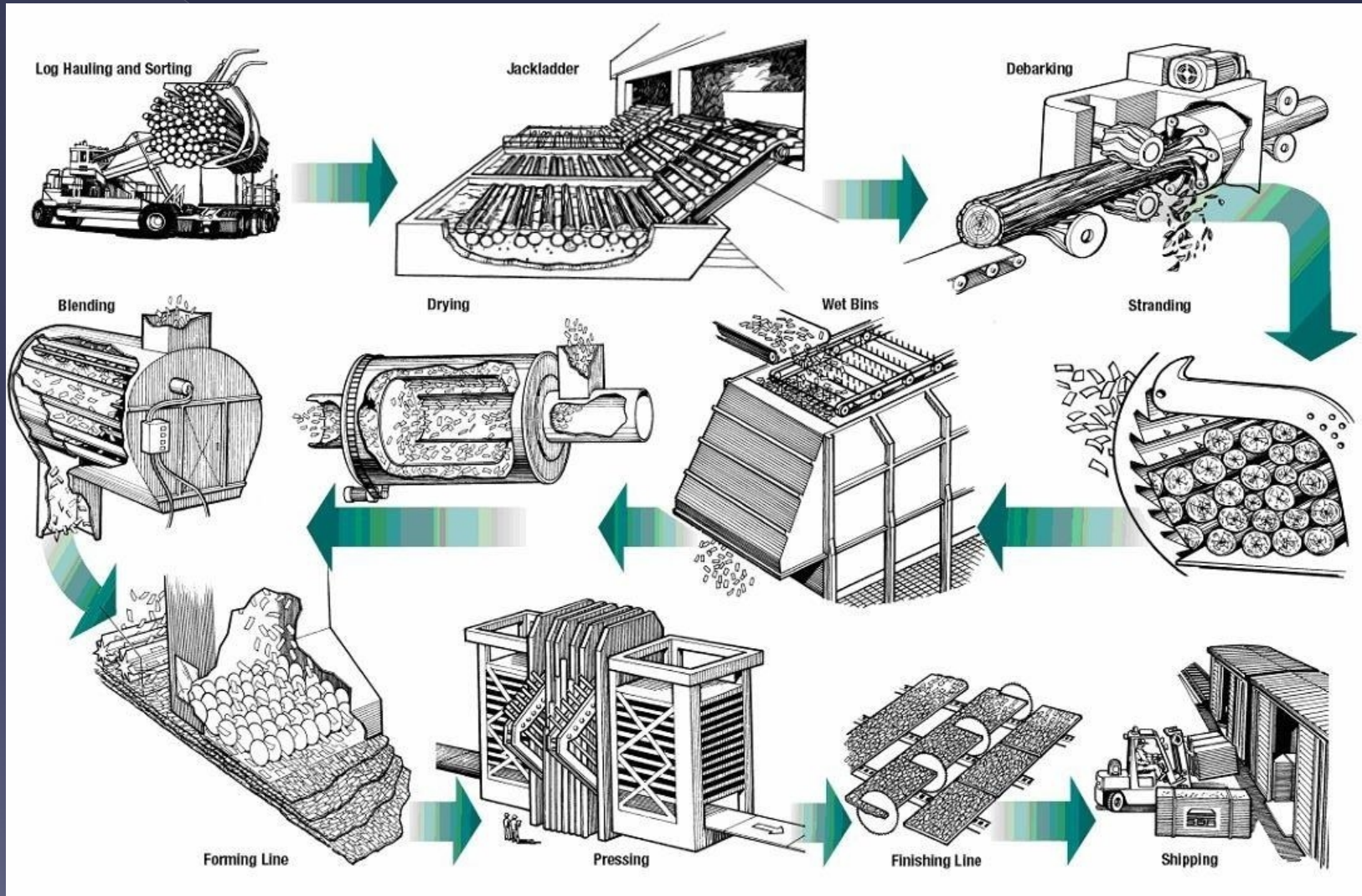



# II) OBJECTIVES OF THE MEASURE

2 mesures for this process

## Adding sawdust in production

Humidity measurement of the sawdust for furnace control

## Manufacturing pannels OSB

Mesure de l'humidité des copeaux pour régulation ajout d'humidité  
Humidity measurement of woodchips for regulation of the humidity adding

# III) TECHNICAL CHARACTERISTICS OF THE APPLICATION

## INSTALLATION

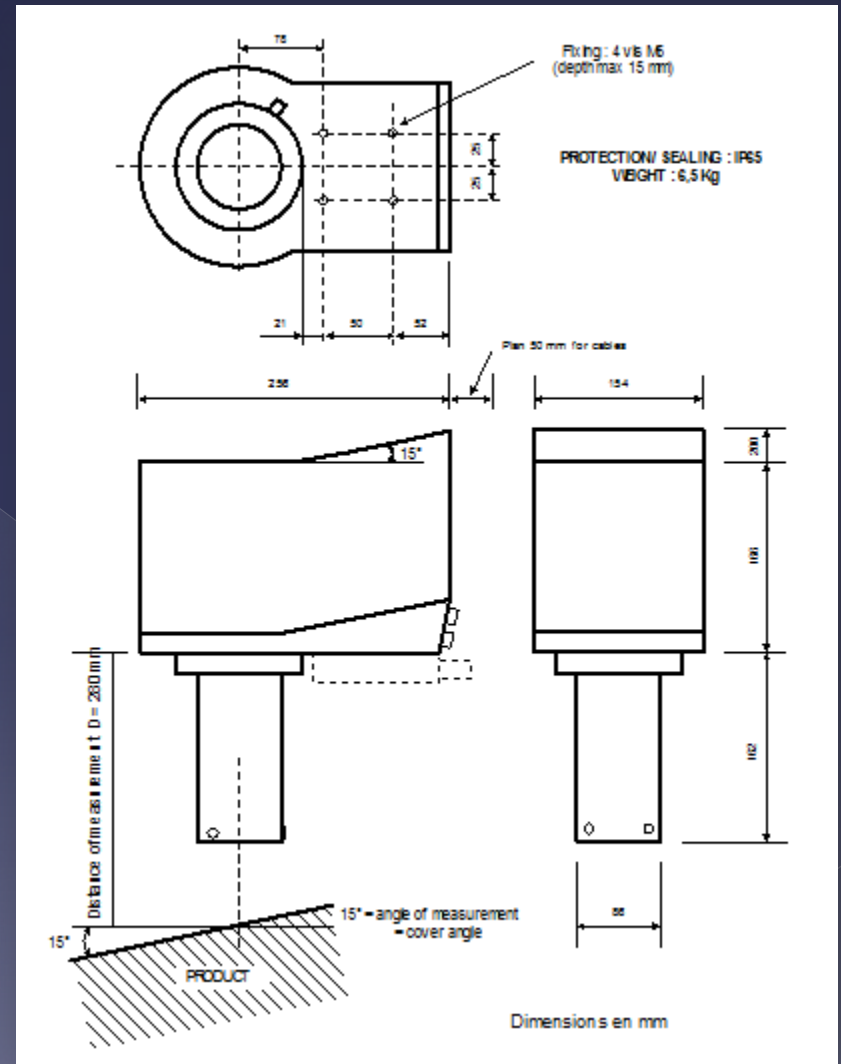



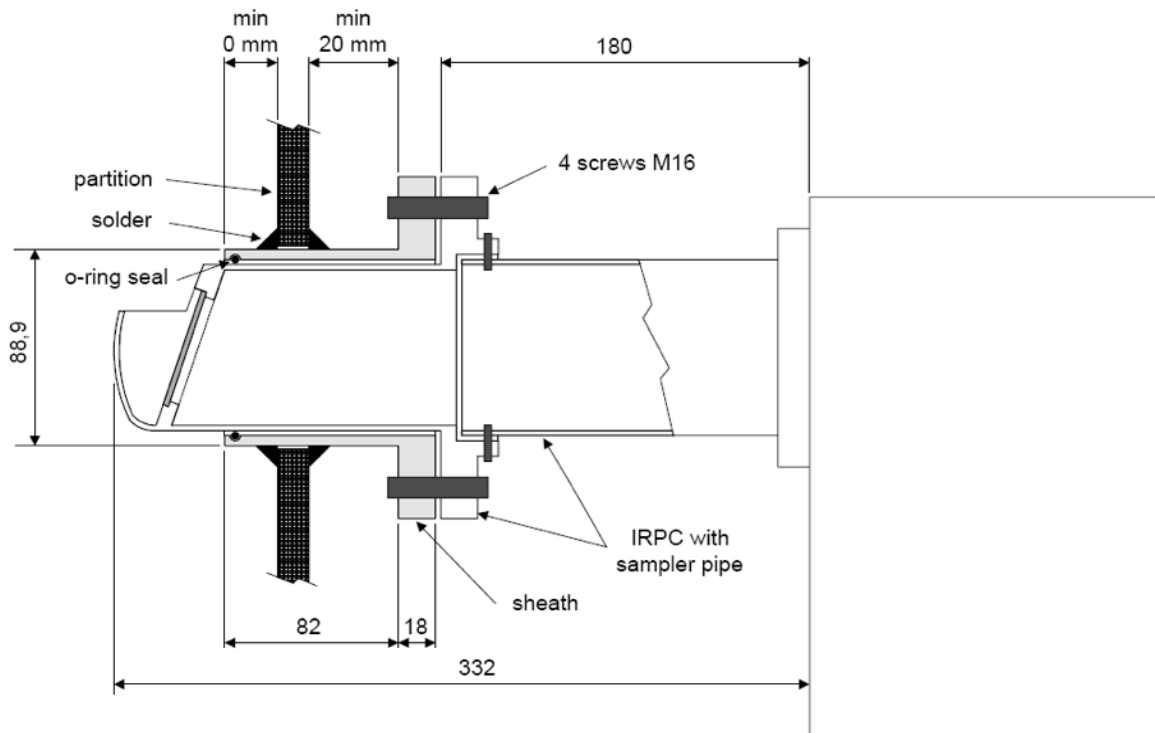





## IV) EDIT NIR SOLUTION

1) Adding sawdust in production

### INFRABELT

- Multifilter wheel
- Calibration plate with its plate
- Cable IRPC 6m (power supply / RS485 / analog output)
- Adaptator RS 232 / RS485
- CD software
- Extra lamp

#### Option

Input / output card

Sampler including PLC

# IV) EDIT NIR SOLUTION

2) Manufacturing pannels OSB

## INFRABELT

- Multifilter wheel
- Calibration plate with its plate
- Cable IRPC 6m (power supply / RS485 / analog output)
- Adaptator RS 232 / RS485
- CD software
- Extra lamp

### Option

Input / output card

Detection cell of product



# V) RESULTS

Measurement of moisture content on sawdust  
Adding sawdust in production

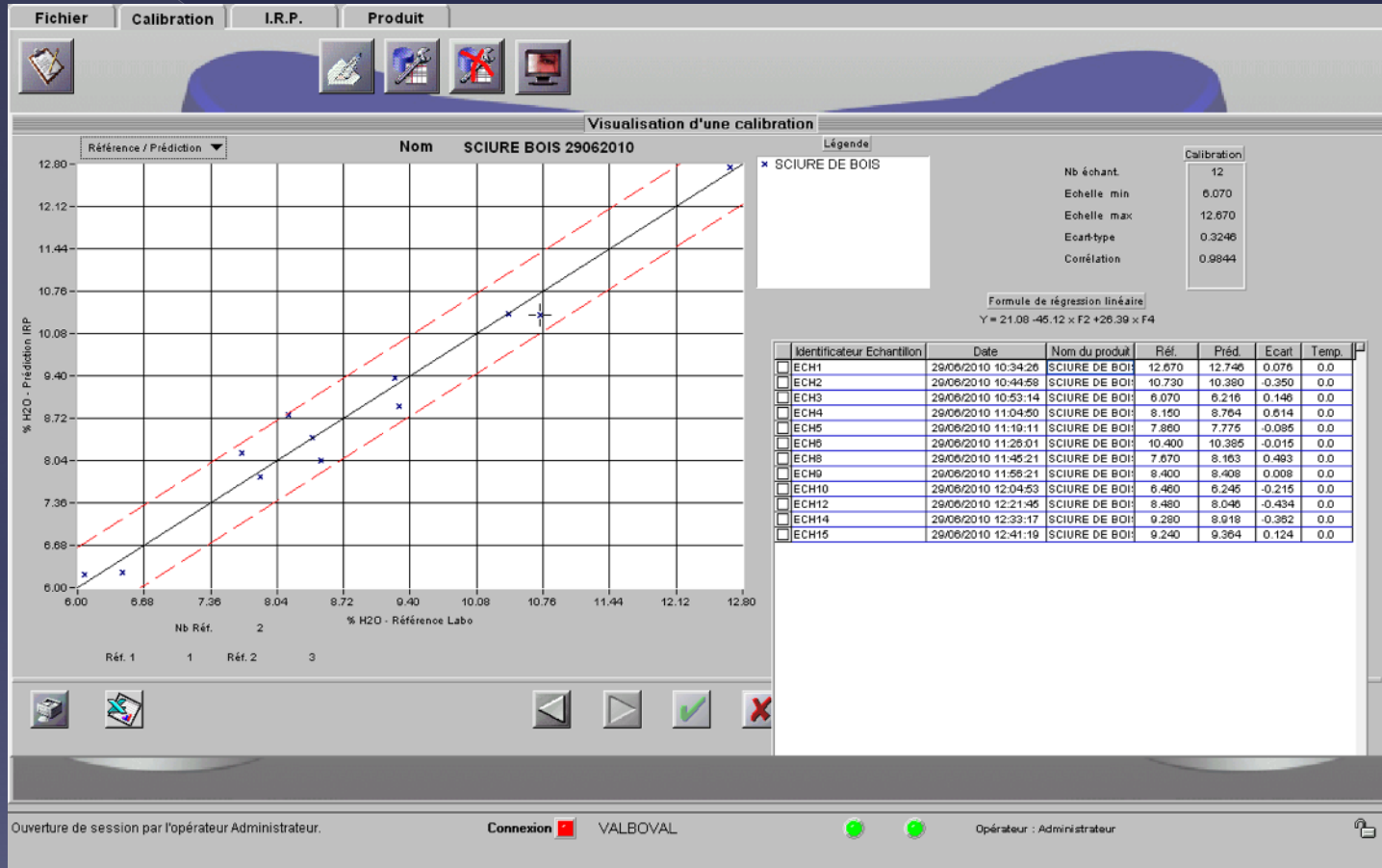

Number of samplers : 12  
Standard deviation : 0,3246  
Reference filters : 1 et 3

Measuring range : 6,07 % à 12,67 %  
Correlation  $R^2 = 0,9844$   
Measurement filters : 2 et 4

# V) RESULTS

## Measurement of moisture content on woodchips Manufacturing panels OSB

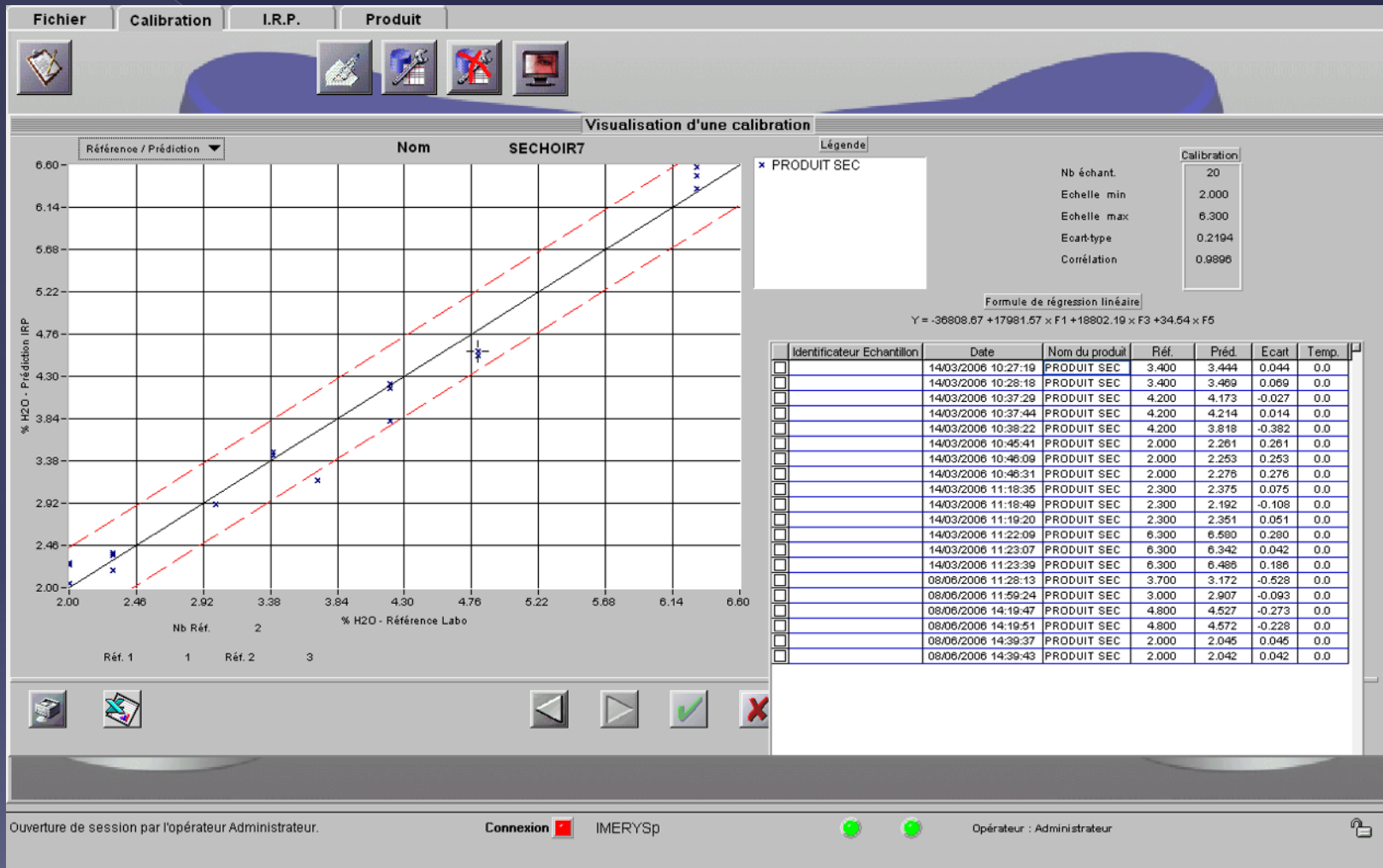

Number of samplers : 20  
Standard deviation : 0,2194  
Reference filters : 1 et 3

Measuring range : 2,00 % à 6,30 %  
Correlation  $R^2 = 0,9896$   
Measurement filters : 1, 3 et 5



# INDUSTRIES AND REFERENCES

## SOME REFERENCES

### ➤ BUILDING MATERIAL INDUSTRIES

Polyrey, Isoroy, Kerlane, Mondi



### ➤ DEVICE QUANTITIES IN France

+ than 10 devices

### ➤ DEVICE QUANTITIES WORLDWIDE

+ than 100 devices

Thank you for your interest !

